

APOLLO XL

TRIMALCO

SGE

**AFFORDABLE
ACCURACY**

www.trimalco.it

MULTI SUBSTRATE

CUTTER

The new Apollo XL can cut materials up to 20mm (3/4") thick. It cuts cleanly, accurately, without dust and without noise and is the most affordable heavy duty cutter available.

The Apollo XL is available in 4 sizes from 165cm (65") to 310cm (122").

FEATURES INCLUDE

- 3 x Quick change tool cartridges.
- An integrated laser sight line (all tools share a common cut line).
- An integral counter balance which reduces operator fatigue and leaves hands free for loading material.
- Two production stops, making repeat cuts for production runs quick and accurate.
- Two Quick Stops for added lateral support.
- A full length clamping system, dual clamps on the 250 and 310 models.
- A 5 year guarantee on all parts except blades and cutting wheels and a 20 year guarantee on the cutting head bearings.

CUTTING CAPABILITIES AS STANDARD

- PVC foam board up to 13mm (1/2")
- Corrugated plastics up to 20mm (3/4")
- Foamboard up to 20mm (3/4")
- Honeycomb board up to 20mm (3/4")
- Most other semi rigid plastics
- Magnetic sheet up to 4mm
- Aluminium composites up to 4mm
- MDF up to 3mm

Plus many more.

USING OPTIONAL TOOLS

- Aluminium Sheets 1mm (.040")
- Score and break acrylic up to 6mm (1/4")
- Score and break glass up to 6mm (1/4")
- V-Groove aluminium composites

We will produce a test cut on request for any of these as well as materials not mentioned.

"The only thing that isn't XL is the price"



NEW CUTTING HEAD

- The all new AXL cutting head takes interchangeable tool cartridges and features a fully integrated laser sightline. The four nylon bearings can be changed easily and are covered by a 20 year guarantee.



QUICK STOPS

- Two Quick Stops provide extra lateral support at whatever height you require. The Quick Stops can also be used for holding boards at an angle if needed.
- Additional Quick Stops can be purchased separately.



PRODUCTION STOPS

- Two production stops LH and RH make repeat cuts for production runs quick and accurate.
- Additional production stops can be purchased separately if required.



SQUARING ARM ADJUSTER BLOCKS

- Two squaring adjuster blocks, LH and RH are fitted as standard. The precise screw adjustment provides a permanent and accurate squaring solution.



OPTIONAL EXTRAS & ACCESSORIES

EXTENSION KIT

- Extension kits for all models can be purchased separately. We don't just extend the squaring arm, we extend the whole machine.



FREE STANDING KIT

- All machines come as standard with a wall mounting bracket. Optional free standing kits can be purchased separately.



SPECIFICATIONS

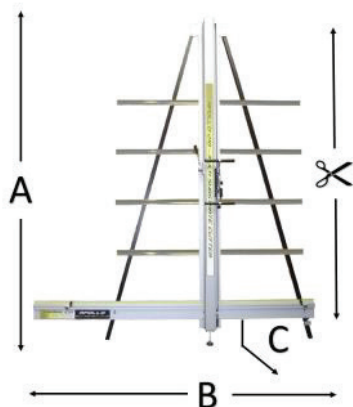

	AXL165	AXL210	AXL250	AXL310
✂ CUT LENGTH	165cm (65")	210cm (83")	250cm (98")	310cm (122")
A	211cm (83")	255cm (100")	294cm (116")	353cm (139")
B	213cm (84")	213cm (84")	213cm (84")	213cm (84")
C	50cm (20")	59cm (23")	68cm (27")	82cm (32")
C	100cm (39")	100cm (39")	140cm (55")	140cm (55")
PACKED WEIGHT	75KG (165LBS)	77KG (169LBS)	83KG (183LBS)	89KG (196LBS)
PACKED DIMENSIONS	271 X 31 X 28cm (107 X 13 X 11")	271 X 31 X 28cm (107 X 13 X 11")	311 X 31 X 28cm (122 X 13 X 11")	371 X 31 X 28cm (146 X 13 X 11")